

Uniclass	EPIC
L41813:P4	D1815:X4
CI/SfB	
(31.59)	Xh

architectural hardware for glass
door handles ⁽³⁾



An exciting range of tubular stainless steel and aluminium handles. Our handles offer the architect or designer a wide range of options and with the majority of handles in stock, we satisfy the needs of the fabricator or installer.



3016

material SS316 stock finish SSS

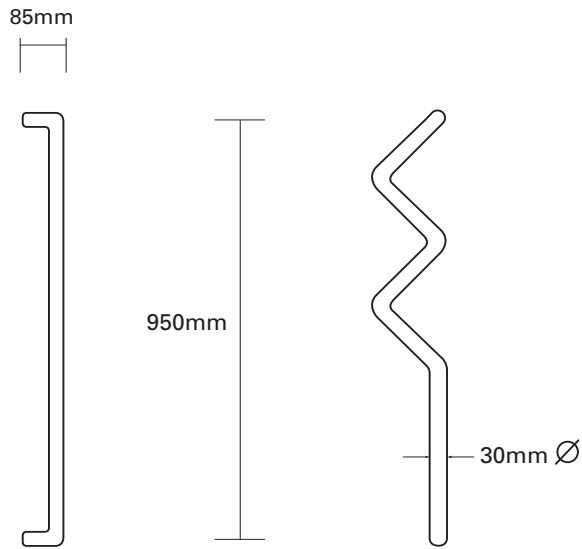

Glass drilling:
2 x 10mm Ø holes

A contemporary design available as a single handle and manufactured from high grade marine stainless steel.

materials and finishes

material	code
Stainless steel grade 304	SS304
Stainless steel grade 316	SS316

stock finishes	code
Polished	PSS
Satin	SSS
Gold PVD	GPVD

NOTES

All handles are supplied in pairs with back to back fixings which are suitable for glass doors. If the handles are to be fitted to timber or aluminium doors then please specify when ordering.

A limited number of designs are available as single handles.

Straight handles must be fixed at least 100mm from the edge of the door to allow for hand clearance.





H16

material SS304 stock finishes PSS, SSS

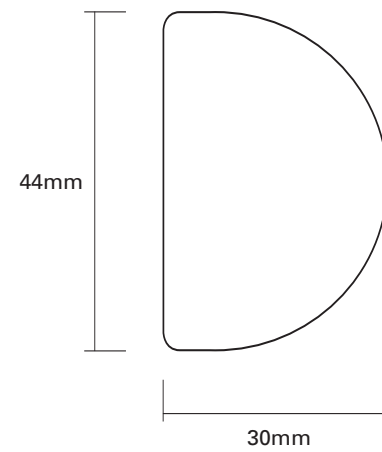
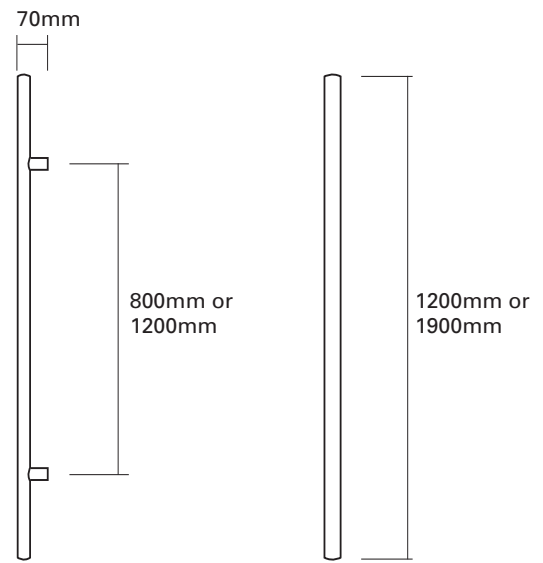

Glass drilling:
2 x 16mm Ø holes

This straight handle is available in two lengths and the tubing is a special 'D' shape. The vertical lines and length of this handle are striking when used in multiple installations.

3015

material SS316 stock finish SSS

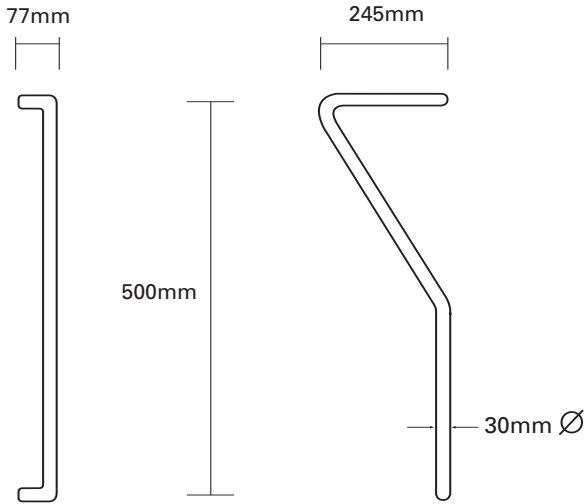

Glass drilling:
2 x 10mm Ø holes

A contemporary design, often specified for double doors. They can be supplied as a single handle and are manufactured from high grade marine stainless steel.



H01

material SS304 stock finishes PSS, SSS

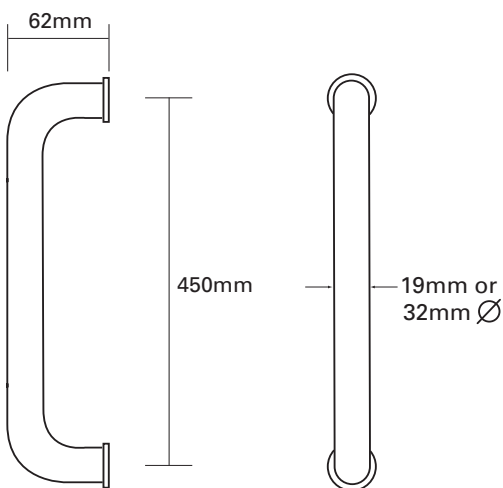

Glass drilling:
2 x 16mm Ø holes

A simple, classic handle designed to complement modern facades.





200B3

material SS316 stock finish SSS

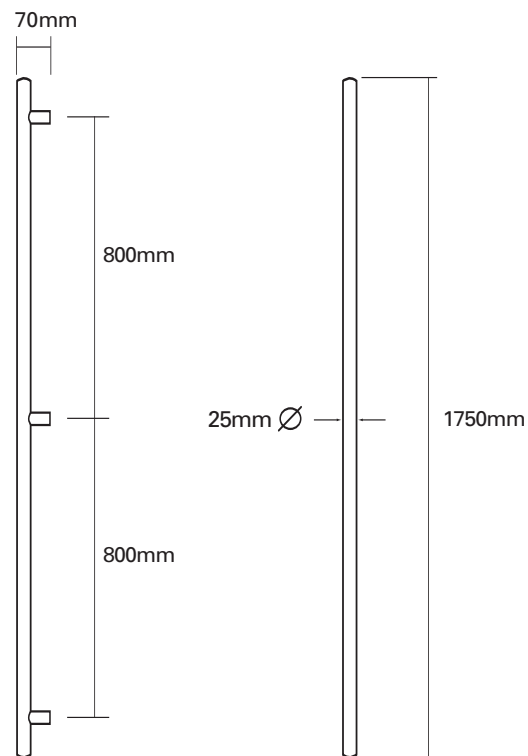

Glass drilling:
3 x 13mm Ø holes

A slim tall 'guardsman' style handle with an additional central fixing point for extra support.

H20

material SS304 stock finishes PSS, SSS

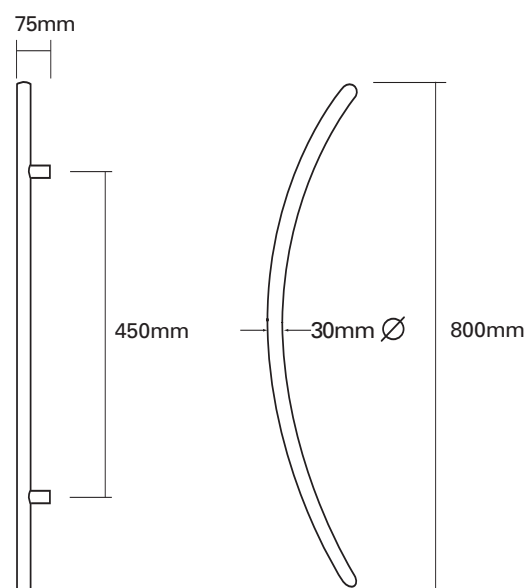

Glass drilling:
2 x 16mm Ø holes

A gently curved handle which can be fitted at 45° across the door.

H17

material SS304 stock finishes PSS, SSS

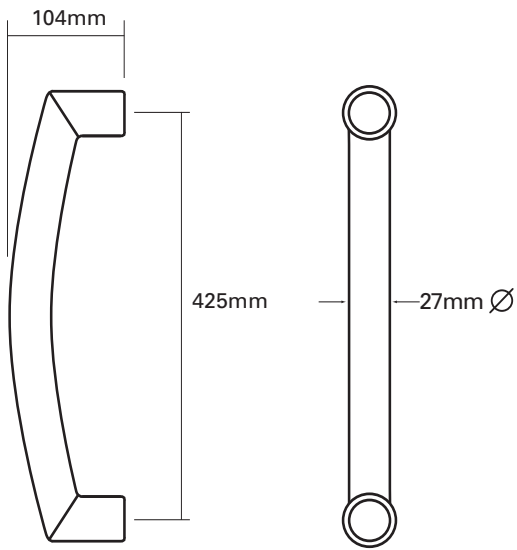

Glass drilling:
2 x 16mm Ø holes

A modern, simple design of handle which looks superb in the satin finish.



H18

material SS304 stock finishes PSS, SSS, GPVD

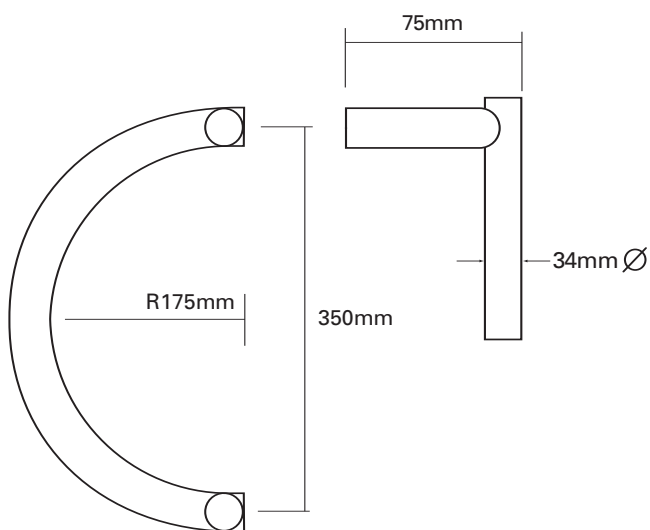

Glass drilling:
2 x 16mm Ø holes

A classic curved handle which is designed, when fitted to double doors, to form a circle.





H03

material SS304 stock finishes PSS, SSS

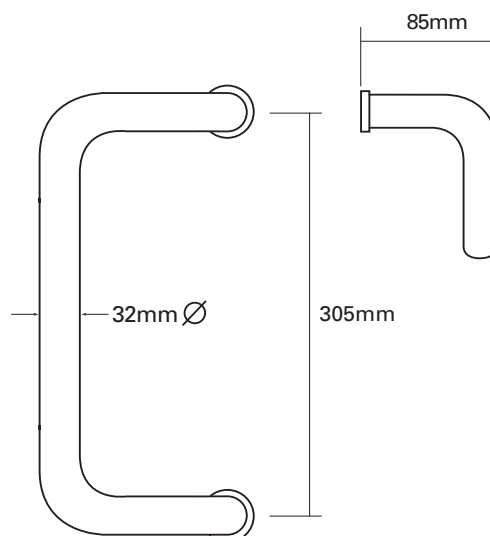

Glass drilling:
2 x 16mm Ø holes

A popular two bend design of handle which is specified mainly for retail installations.



H04

material SS304 stock finishes PSS, SSS

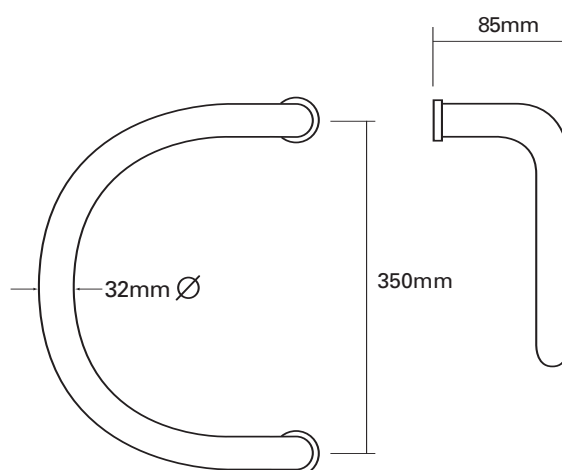

Glass drilling:
2 x 16mm Ø holes

This curved handle offers a really impressive appearance particularly in the polished finish.

218

material SS316 stock finish SSS

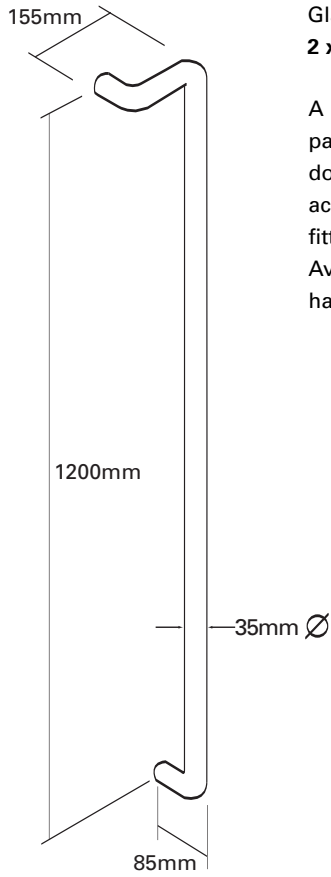

Glass drilling:
2 x 13mm Ø holes

A heavy duty handle particularly suitable for doors with wheelchair access where low level fitting is required. Available as a single handle.

200B

material SS316 stock finish SSS

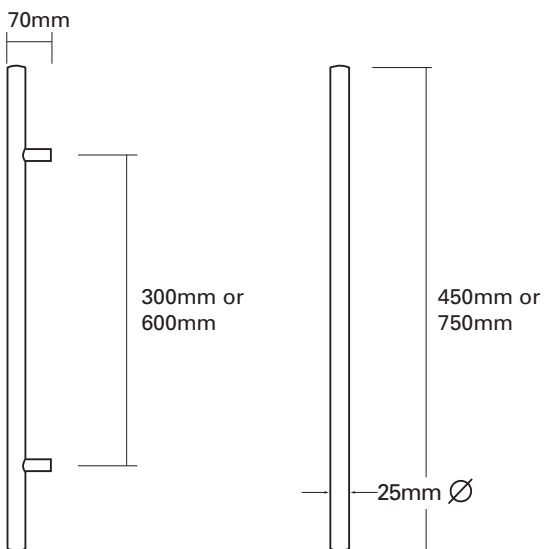

Glass drilling:
2 x 13mm Ø holes

A 'Guardsmen' style handle suitable for swing and sliding doors. Available as a single handle.



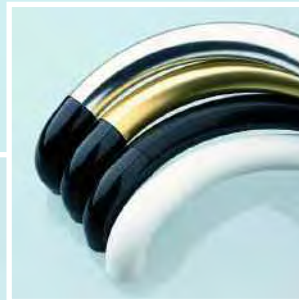

V01

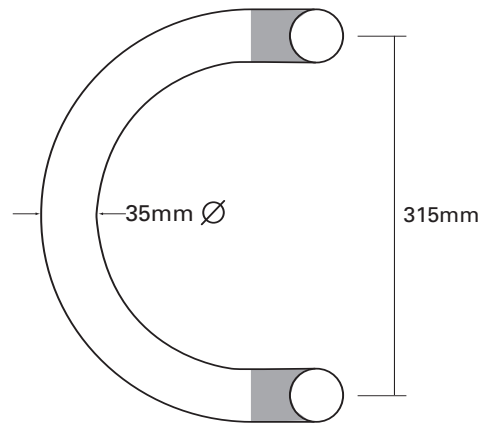

Glass drilling:
2 x 10mm Ø holes

V Series

These budget handles are available in two designs and manufactured from specially extruded aluminium tube with moulded nylon elbows. Available as single handles.

Limited stock, please check before ordering.

finishes

- Mill with black or white elbows
- Silver anodised with black elbows
- Gold anodised with black elbows
- All black
- All white

V05

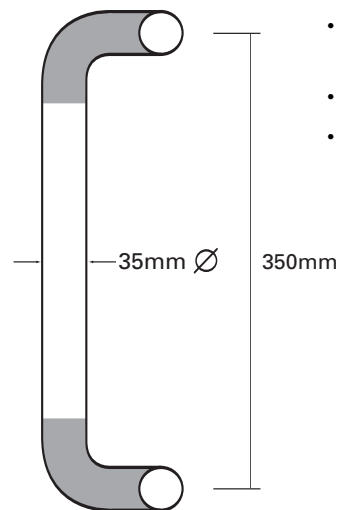

Cleaning notes The hardware featured in this brochure requires little or no maintenance but to retain the finished surfaces the following guidelines apply; Routine cleaning with mild soap, ammonia or detergent and warm water. Rinse with clean water and wipe dry to avoid water marks.

Do not use any abrasive cleaners. A regular application of Autoglym Super Resin Polish helps reduce attack by pollution, dirt and abrasion.

Peterlee Glass Company Ltd.
28 Lister Rd,
North West Industrial Estate,
Peterlee,
County Durham.
SR8 2RB
Tel: +44 (0)191 586 4626.
Fax: +44 (0)191 518 0459.
www.peterleeglass.com